



FAA-500-CB Built-in housing for concrete ceilings



FAA-500-CB built-in housings are used to install 500 and 520 series detectors in concrete ceilings. These make it possible to position cable ducts with ease and precision. A ceiling mount back box is installed in the built-in housing which receives the base and the detector.

Ordering Information

FAA-500-CB Built-in housing for concrete ceilings FAA-500-CB

System Overview

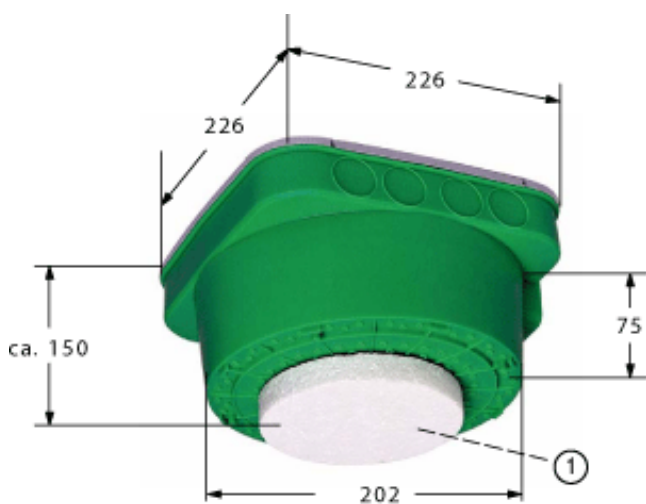

Pos.	Description
1	Front part