



# EMK 46 Z Built-in magnetic contact



- ▶ Conventional built-in magnetic contact
- ▶ VdS class B
- ▶ Head-on or parallel installation
- ▶ Conventional perimeter protection

Conventional magnet contacts are used for tear-off surveillance of doors and windows.

## Certifications and Approvals

Country	Certification	EMK 46 Z
DE	VdS	G 191564, B

## Installation/Configuration Notes

Magnetic contact and magnet are mounted in parallel or head-on to each other. Installation can be done optionally with or without plastic sleeves. If no plastic sleeve is used, the built in parts should be fixed in the holes.

**Installation in ferromagnetic materials is not permissible.**

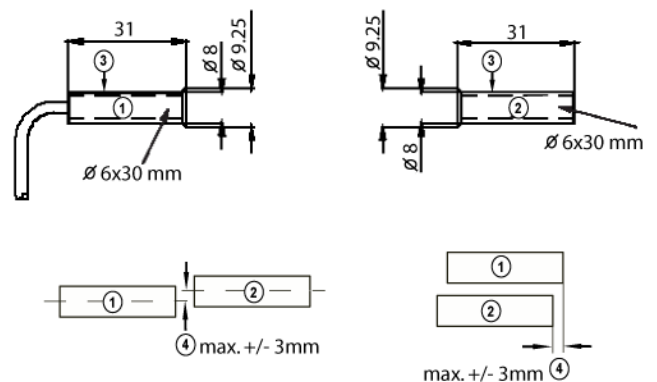

- 1 Contact
- 2 Magnet
- 3 Sleeve
- 4 Installation offset

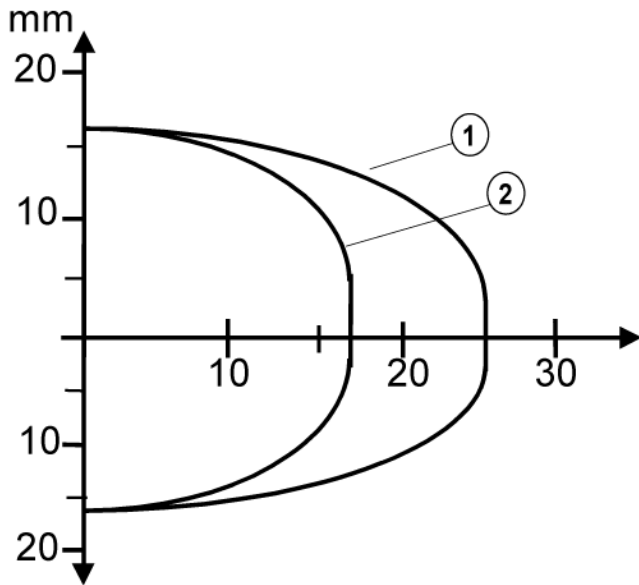

- 1 Extraction
- 2 Proximity switch part

**Connection cable/terminal strip**

The supply lines need to be measured electrically before connection.

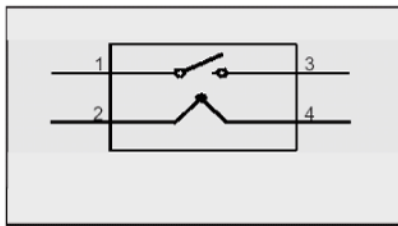
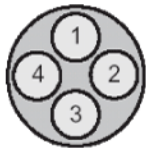

**Technical Specifications**

Type of installation	Installation, head-on or parallel
Permitted operating voltage	max. 40 V <sub>-</sub>
Contact type	1-pin open contact
Permitted contact load	6 VA max. 100 V max. 500 mA
Protective system	IP 67 VdS environmental class IV
Permissible ambient temperature	-25 °C to +70 °C
Case Material	ABS
Color	White
Dimensions	
Contact	6 x 30 mm (Ø x L)
Magnet (W x H x L)	6 x 30 mm (Ø x L)
Plastic sleeve	8 x 31 mm (Ø x L)
Connection cable	Ø 3.2 mm, 6 m long

**Ordering Information**

EMK 46 Z Built-in magnetic contact 4998026047

**Parts Included**

Type	Qty.	Components
EMK 46 Z	1	Built in magnetic contact incl. flange and sleeves

**Americas:**  
 Bosch Security Systems  
 130 Perinton Parkway  
 Fairport, New York, 14450, USA  
 Phone: +1 585 223 4060  
 Fax: +1 800 289 0096  
 security.sales@us.bosch.com  
 www.boschsecurity.us

**Europe, Middle East, Africa:**  
 Bosch Security Systems B.V.  
 P.O. Box 80002  
 5600 JB Eindhoven, The Netherlands  
 Phone: +31 40 27 83955  
 Fax: +31 40 27 86668  
 emea.securitysystems@bosch.com  
 www.boschsecurity.com

**Asia-Pacific:**  
 Bosch Security Systems Pte Ltd  
 38C Jalan Pemimpin  
 Singapore 577180  
 Phone: +65 6319 3450  
 Fax: +65 6319 3499  
 apr.securitysystems@bosch.com  
 www.boschsecurity.com

**Represented by**